



## NBE-5AC-Gen2 Quick Start Guide

### Package Contents



NanoBeam 5AC Gen 2



Ball Joint Mount



Lock Ring



Metal Strap



Gigabit PoE (24V, 0.5A) with  
Mounting Bracket



Power Cord

### Installation Requirements

- Pole-mounting: 7 mm socket wrench or screwdriver
- Wall-mounting: wall fastener (not included)
- Shielded Category 5 (or above) cabling with drain wire should be used for all wired Ethernet connections and should be grounded through the AC ground of the PoE. We recommend that you protect your networks from harmful outdoor environments and destructive ESD events with industrial-grade, shielded Ethernet cable from Ubiquiti. For more details, visit [ui.com/toughcable](https://ui.com/toughcable)
- Surge protection should be used for all outdoor installations. We recommend that you use two Ethernet Surge Protectors, model ETH-SP, one near the NanoBeam and the other at the entry point to the building. The ETH-SP will absorb power surges and safely discharge them into the ground.



# NBE-5AC-Gen2 Quick Start Guide

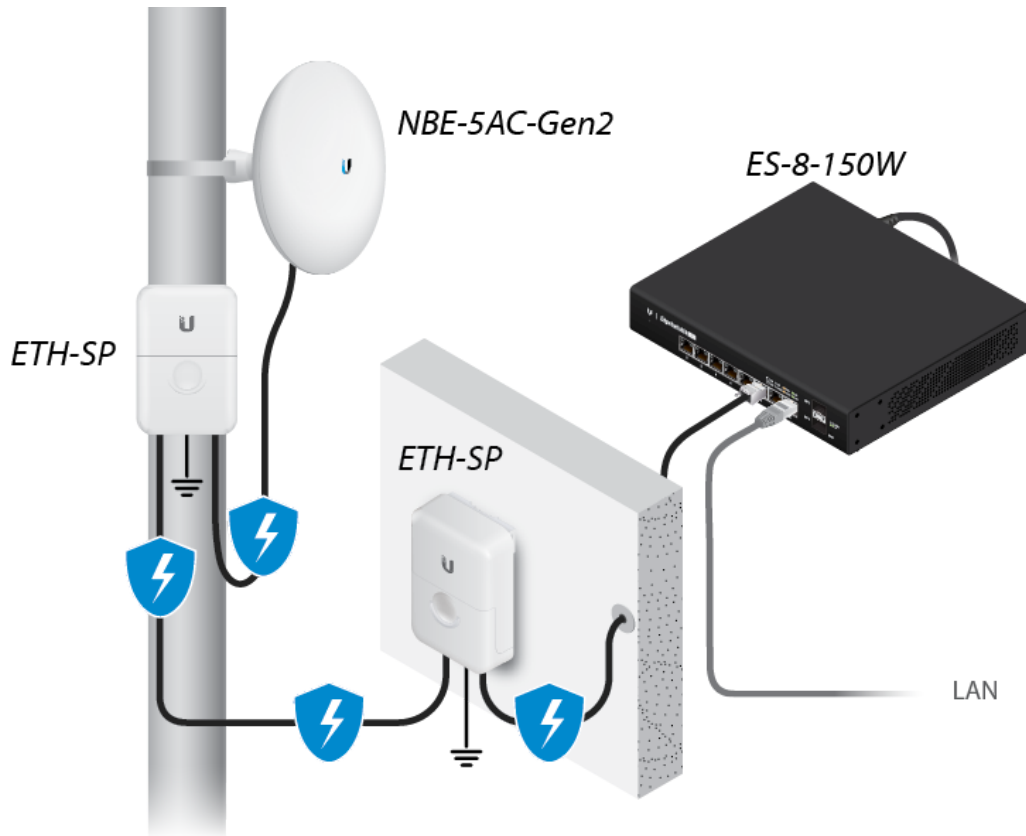

## Hardware Overview

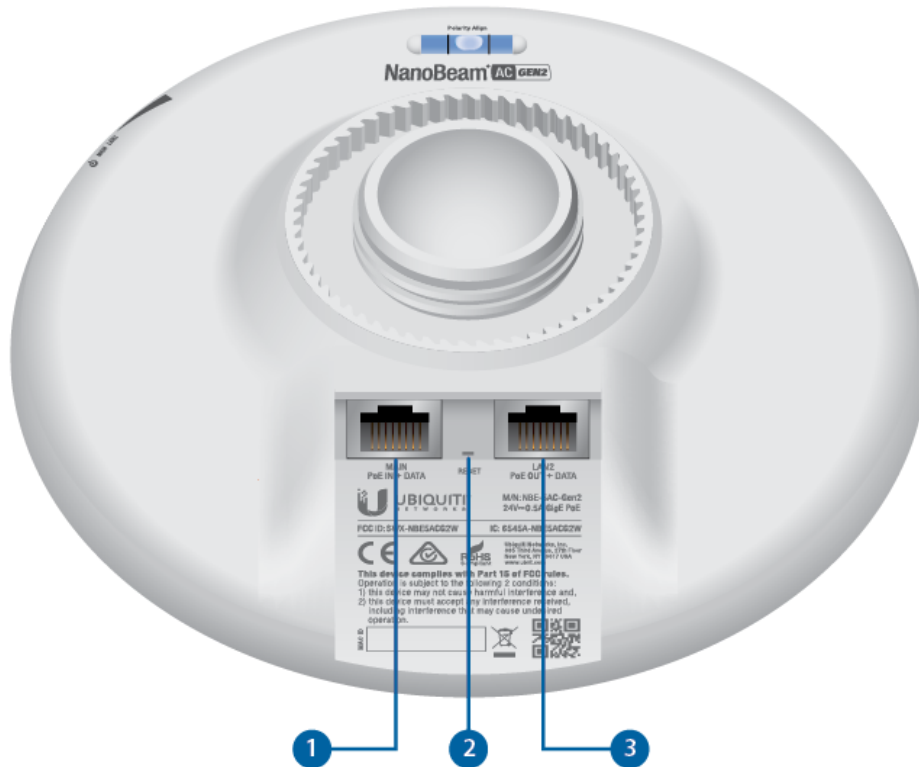



## NBE-5AC-Gen2 Quick Start Guide

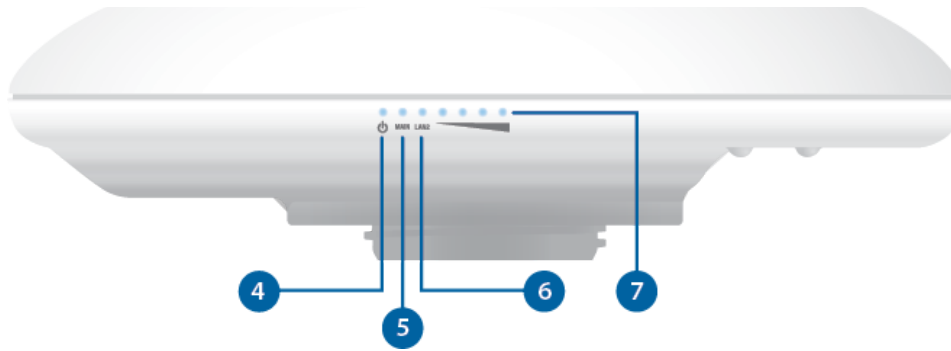

### 1 Main Ethernet Port

This Gigabit Ethernet port is used to connect the power and should be connected to the LAN and DHCP server.

### 2 Reset Button

To reset to factory defaults, press and hold the Reset button for more than 10 seconds while the device is powered on. Alternatively, the device may be reset remotely via a Reset button located on the bottom of the Gigabit PoE Adapter.

### 3 Secondary Ethernet Port

This Gigabit Ethernet port provides passthrough PoE to power and connect a 24V passive PoE device to the network.



**Note:** In order to use PoE Passthrough on the Secondary port, a 24V, 1A PoE adapter is required.

### 4 Power LED

The Power LED will light blue when the device is connected to a power source.

### 5 Main LED

The LED will light steady blue when an active Ethernet connection is made to the Main port and flash when there is activity.

### 6 LAN2 LED

The LED will light steady blue when an active Ethernet connection is made to the LAN2 port and flash when there is activity.

### 7 Signal LEDs

In airOS®, you can modify the threshold value for the wireless signal strength LEDs on the Wireless tab under Signal LED Thresholds. Each LED will light when the



## NBE-5AC-Gen2 Quick Start Guide

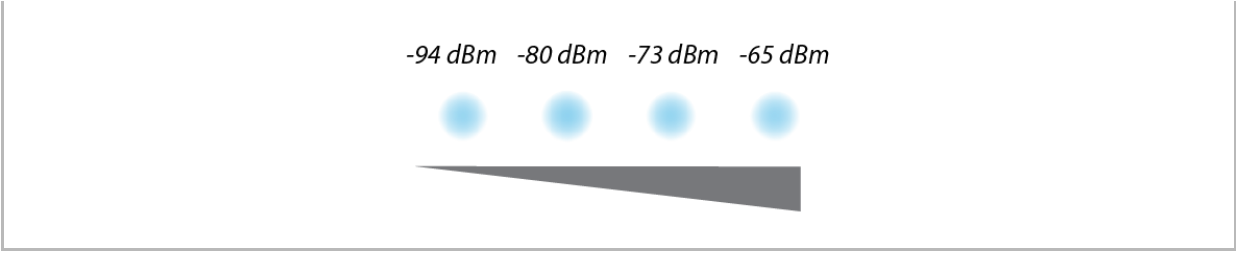

### Hardware Installation

Go to the appropriate mounting instructions: Pole Mounting or ["Wall Mounting"](#).

#### Pole Mounting

1.



2.

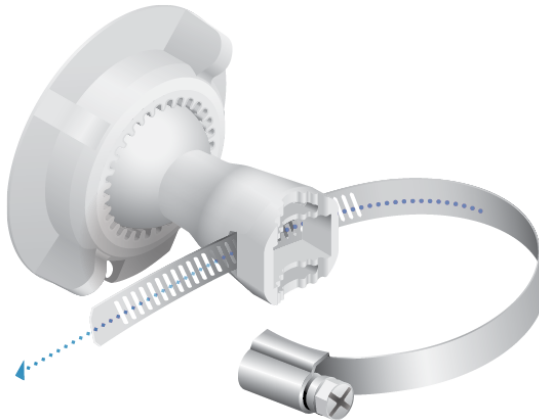

3.



## NBE-5AC-Gen2 Quick Start Guide

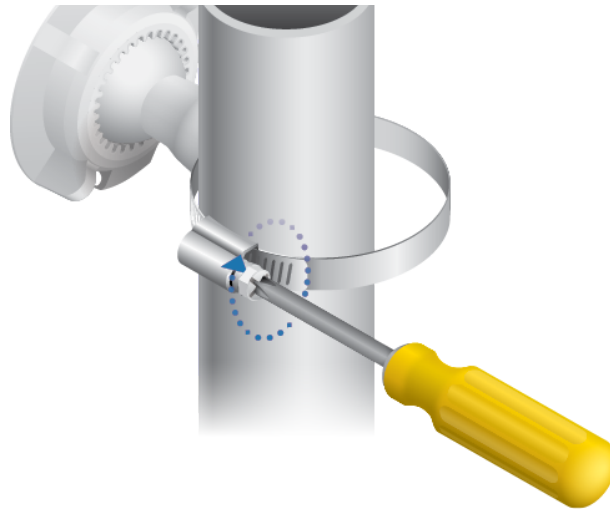

4.

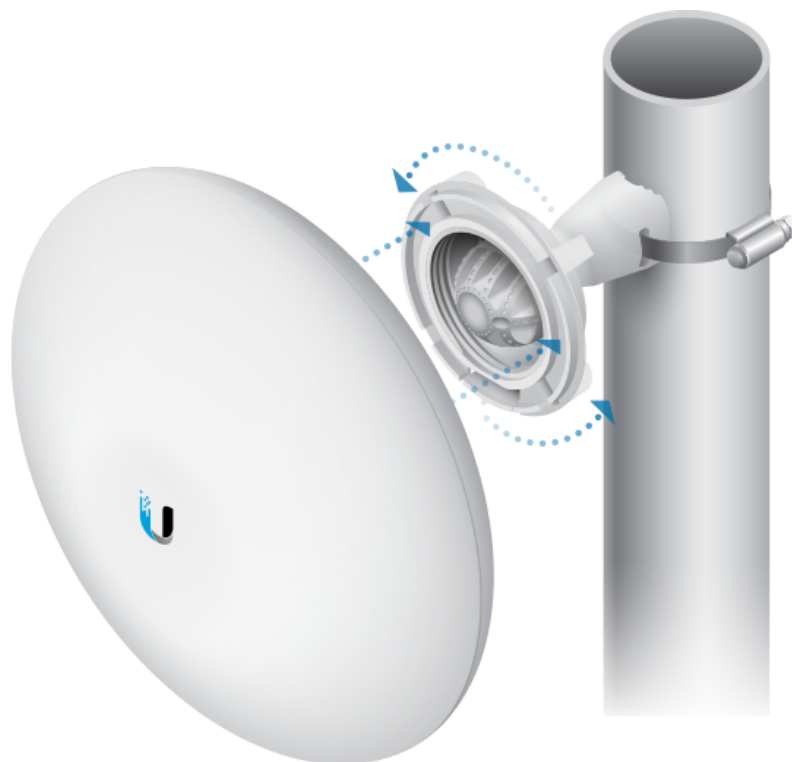

## Wall Mounting

The NanoBeam must be mounted directly to a wood stud or other structurally stable surface to avoid damage to the mounting hole when you adjust the aim.

## Optional Accessory

To enhance stability, you can use the NanoBeam Wall Mount Kit, model NBE-WMK (sold separately).

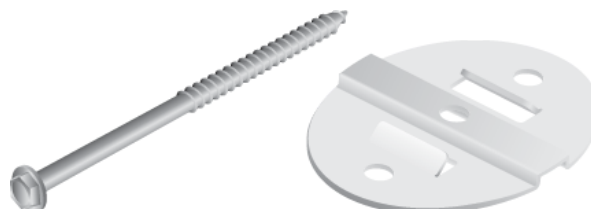



## NBE-5AC-Gen2 Quick Start Guide

### Installation Instructions

1.

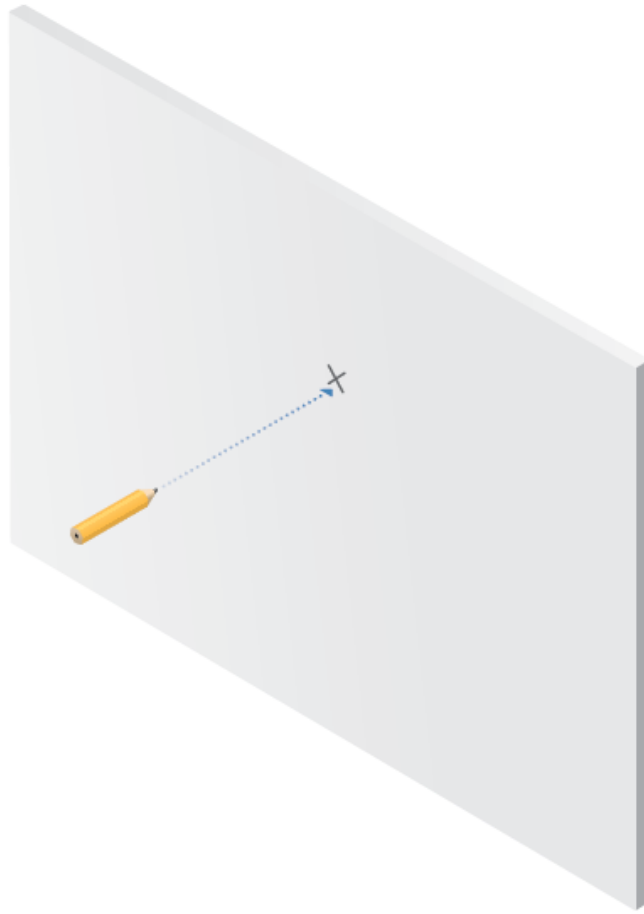

2.



# NBE-5AC-Gen2 Quick Start Guide



3.

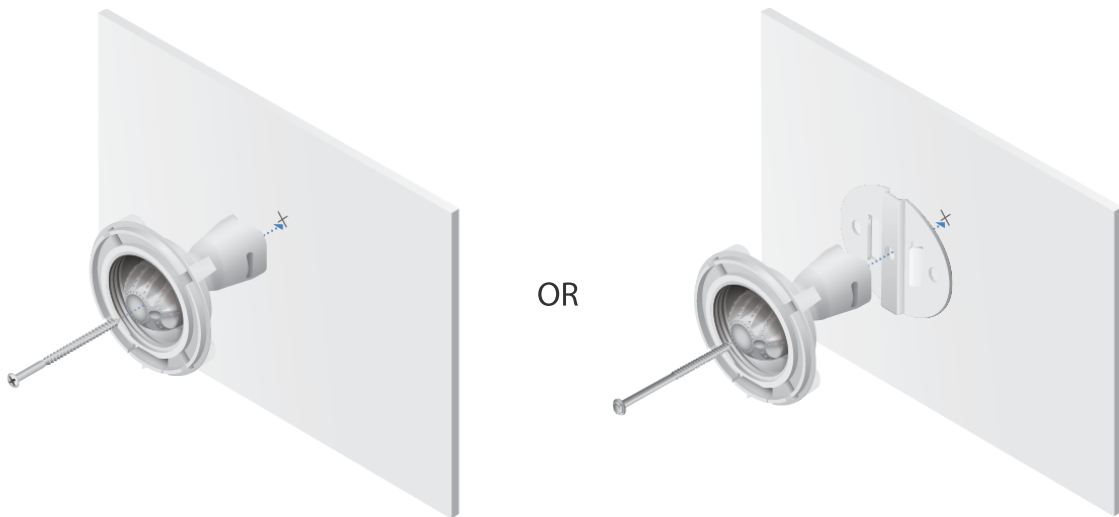

*Fastener (not included)*

*NanoBeam Wall Mount Kit*

4.



## NBE-5AC-Gen2 Quick Start Guide

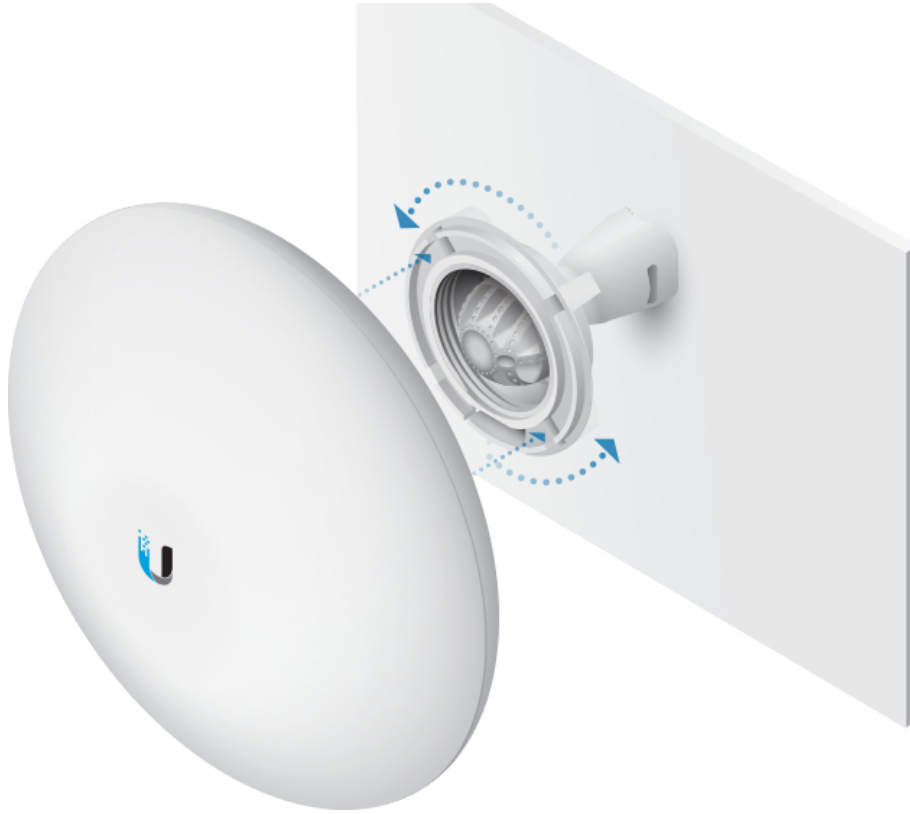

### Aiming

1.

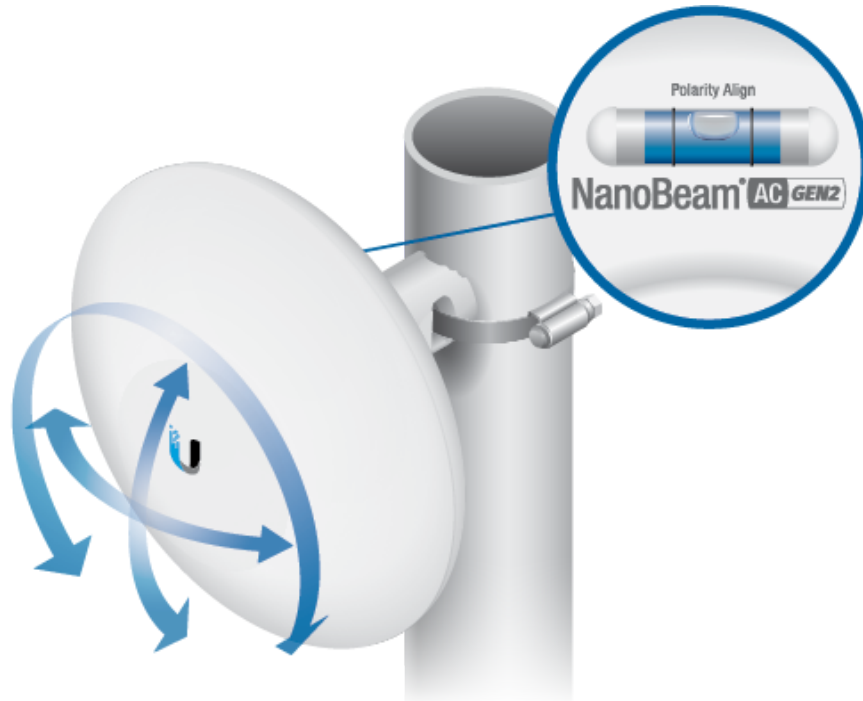

2.



## NBE-5AC-Gen2 Quick Start Guide

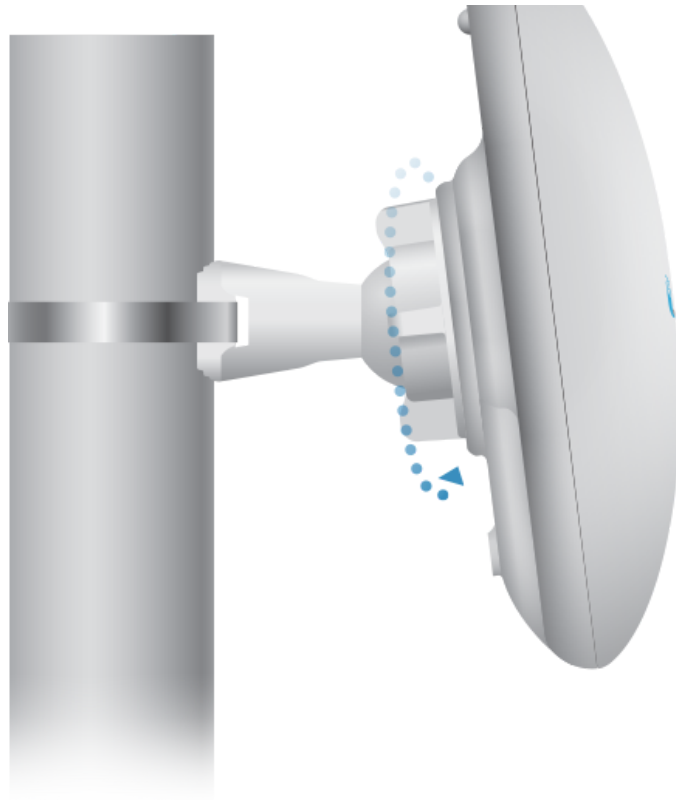

### Connecting Power

1.

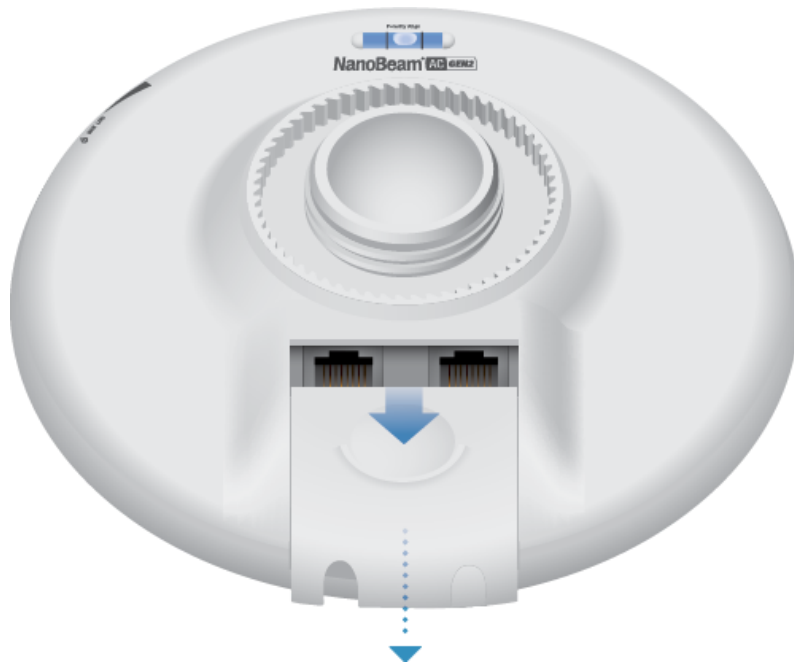

2.



# NBE-5AC-Gen2 Quick Start Guide



3.



4.



**WARNING:** The switch port must comply with the power specifications listed in this Quick Start Guide.



## NBE-5AC-Gen2 Quick Start Guide



OR

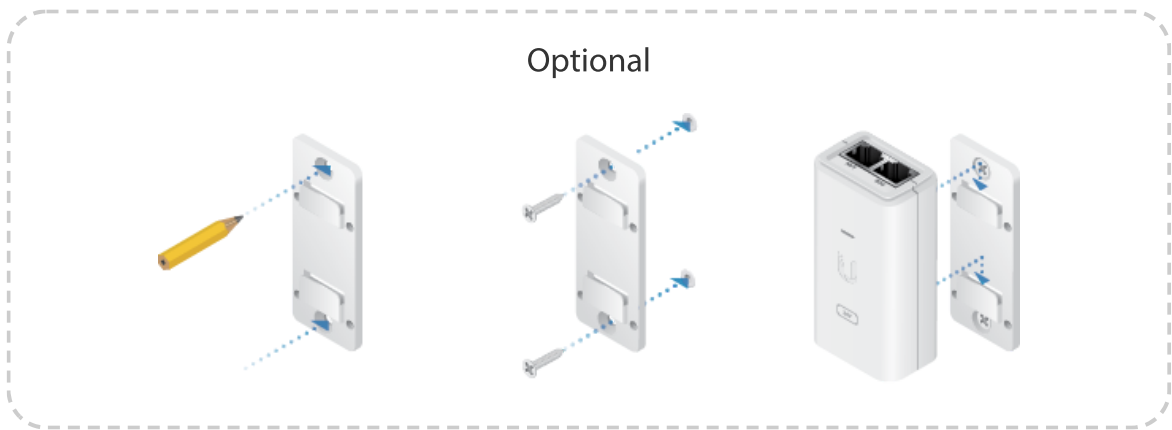
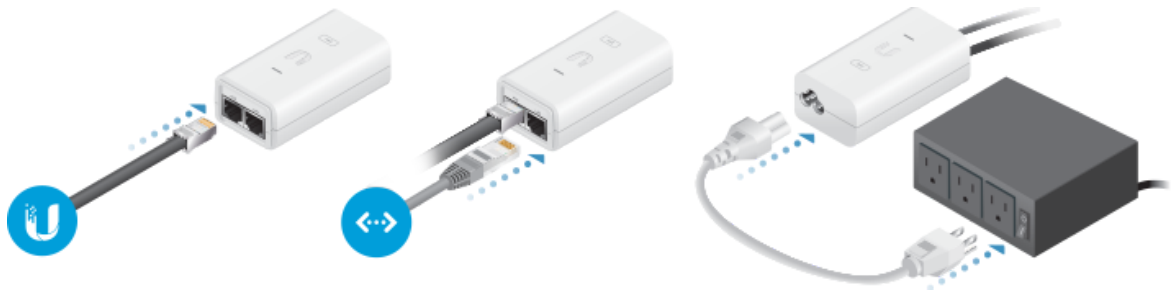

## Accessing airOS via Wi-Fi

Verify connectivity in the airOS® Configuration Interface using the UNMS™ app or Web Portal. Both are available for 15 minutes immediately after you power on the device. If necessary, you can power cycle the device to re-enable its Wi-Fi.

### UNMS App

1. Download the UNMS app.



## NBE-5AC-Gen2 Quick Start Guide



2. Connect your device's Wi-Fi to the SSID named: <model>:<MAC Address>



**Note:** Ensure that DHCP is enabled on your Wi-Fi adapter.

3. Launch the app and follow the on-screen instructions.

### Web Portal

1. Connect your device's Wi-Fi to the SSID named: <model>:<MAC Address>



**Note:** Ensure that your Wi-Fi connection has DHCP enabled.

2. Launch your web browser and go to: <http://setup.ui.com>



3. Select your Country and Language. You must agree to the Terms of Use to use the product. Click Continue.

4. Create a username and password. Confirm your new password and then click Save.



## NBE-5AC-Gen2 Quick Start Guide



The airOS Configuration Interface will appear, allowing you to customize your settings as needed. For additional details, refer to the User Guide available at [ui.com/download/airmax-ac](http://ui.com/download/airmax-ac)

## Installer Compliance Responsibility

Devices must be professionally installed and it is the professional installer's responsibility to make sure the device is operated within local country regulatory requirements.

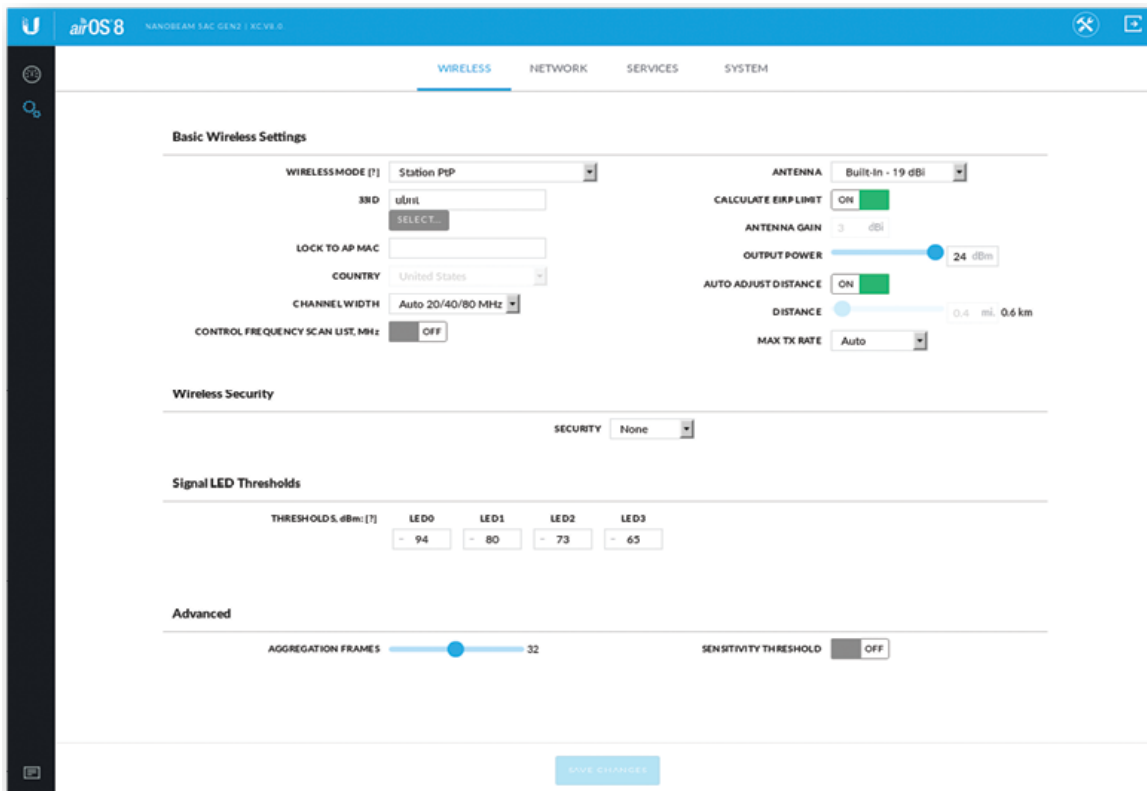



## NBE-5AC-Gen2 Quick Start Guide

## Specifications

NBE-5AC-Gen2	
Dimensions	189 x 189 x 125 mm (7.44 x 7.44 x 4.92")
Weight	530 g (1.17 lb)
Gain	17 dBi
Networking Interface	(2) 10/100/1000 Ethernet Ports Wi-Fi for Management
Enclosure	Outdoor UV Stabilized Plastic
Max. Power Consumption	8.5W
Power Supply	24V, 0.5A Gigabit PoE Adapter (Included)
Power Method	24V Passive PoE In (Pairs 4, 5+; 7, 8 Return)
PoE Passthrough	24V Passive PoE Out (Pairs 4, 5+; 7, 8 Return)
Wind Loading	45.4 N @ 200 km/h (10.2 lbf @ 125 mph)
Wind Survivability	200 km/h (125 mph)
Operating Temperature	-40 to 80° C (-40 to 176° F)
Operating Humidity	5 to 95% Noncondensing
Salt Fog Test	IEC 68-2-11 (ASTM B117), Equivalent: MIL-STD-810 G Method 509.5
Vibration Test	IEC 68-2-6
Temperature Shock Test	IEC 68-2-14
UV Test	IEC 68-2-5 at 40° C (104° F) Equivalent: ETS 300 019-1-4
Wind-Driven Rain Test	ETS 300 019-1-4 Equivalent: MIL-STD-810 G Method 506.5
Mounting	Pole-Mount (Kit Included) Wall-Mount (Not Included)
ESD/EMP Protection	± 24kV Contact/Air
Certifications	CE, FCC, IC

Operating Frequency (MHz)	
Worldwide	5150 - 5875
US/CA	U-NII-1 5150 - 5250



## NBE-5AC-Gen2 Quick Start Guide

	U-NII-2C	5470 - 5725
	U-NII-3	5725 - 5850
Management Radio (MHz)		
Worldwide		2412 - 2472
US/CA		2412 - 2462

## Safety Notices

1. Read, follow, and keep these instructions.
2. Heed all warnings.
3. Only use attachments/accessories specified by the manufacturer.



**WARNING:** Do not use this product in location that can be submerged by water.



**WARNING:** Avoid using this product during an electrical storm. There may be a remote risk of electric shock from lightning.

## Electrical Safety Information

1. Compliance is required with respect to voltage, frequency, and current requirements indicated on the manufacturer's label. Connection to a different power source than those specified may result in improper operation, damage to the equipment or pose a fire hazard if the limitations are not followed.
2. There are no operator serviceable parts inside this equipment. Service should be provided only by a qualified service technician.
3. This equipment is provided with a detachable power cord which has an integral safety ground wire intended for connection to a grounded safety outlet.
  - a. Do not substitute the power cord with one that is not the provided approved type. Never use an adapter plug to connect to a 2-wire outlet as this will defeat the continuity of the grounding wire.
  - b. The equipment requires the use of the ground wire as a part of the safety certification, modification or misuse can provide a shock hazard that can result in serious injury or death.
  - c. Contact a qualified electrician or the manufacturer if there are questions about the installation prior to connecting the equipment.
  - d. Protective earthing is provided by Listed AC adapter. Building installation shall provide appropriate short-circuit backup protection.
  - e. Protective bonding must be installed in accordance with local national wiring rules and regulations.

## Limited Warranty

[ui.com/support/warranty](https://ui.com/support/warranty)



## NBE-5AC-Gen2 Quick Start Guide

# Compliance

## FCC

Changes or modifications not expressly approved by the party responsible for compliance could void the user's authority to operate the equipment.

This device complies with Part 15 of the FCC Rules. Operation is subject to the following two conditions.

1. This device may not cause harmful interference, and
2. This device must accept any interference received, including interference that may cause undesired operation.

This equipment has been tested and found to comply with the limits for a Class A digital device, pursuant to part 15 of the FCC Rules. These limits are designed to provide reasonable protection against harmful interference when the equipment is operated in a commercial environment. This equipment generates, uses, and can radiate radio frequency energy and, if not installed and used in accordance with the instruction manual, may cause harmful interference to radio communications. Operations of this equipment in a residential area is likely to cause harmful interference in which case the user will be required to correct the interference at his own expense.

This radio transmitter has been approved by FCC.

## ISED Canada

### CAN ICES-3(A)/NMB-3(A)

This device complies with ISED Canada licence-exempt RSS standard(s). Operation is subject to the following two conditions:

1. This device may not cause interference, and
2. This device must accept any interference, including interference that may cause undesired operation of the device.

This radio transmitter has been approved by ISED Canada.

The device for operation in the band 5150-5250 MHz is only for indoor use to reduce the potential for harmful interference to co-channel mobile satellite systems.

### CAN ICES-3(A)/NMB-3(A)

Le présent appareil est conforme aux CNR d'ISDE Canada applicables aux appareils radio exempts de licence. L'exploitation est autorisée aux deux conditions suivantes :

1. l'appareil ne doit pas produire de brouillage;
2. l'appareil doit accepter tout brouillage radioélectrique subi, même si le brouillage est susceptible d'en compromettre le fonctionnement.

Le présent émetteur radio a été approuvé par ISDE Canada.

Les dispositifs fonctionnant dans la bande 5150-5250 MHz sont réservés uniquement pour une utilisation à l'intérieur afin de réduire les risques de brouillage préjudiciable aux systèmes de satellites mobiles utilisant les mêmes canaux.

## IMPORTANT NOTE



## NBE-5AC-Gen2 Quick Start Guide

- This equipment complies with radiation exposure limits set forth for an uncontrolled environment.
- This equipment should be installed and operated with minimum distance 29 cm between the radiator and your body.
- This transmitter must not be co-located or operating in conjunction with any other antenna or transmitter.

## AVIS IMPORTANT

### Déclaration sur l'exposition aux rayonnements

- Cet équipement est conforme aux limites prévues pour l'exposition aux rayonnements dans un environnement non contrôlé.
- Lors de l'installation et de la mise en fonctionnement de l'équipement, assurez-vous qu'il y ait une distance minimale de 29 cm entre l'élément rayonnant et vous.
- Cet émetteur ne doit être installé à proximité d'aucune autre antenne ni d'aucun autre émetteur, et ne doit être utilisé conjointement à aucun autre de ces appareils.

### Australia and New Zealand



Warning: This equipment is compliant with Class A of CISPR 32. In a residential environment this equipment may cause radio interference.

### Brazil



**Nota:** Este equipamento não tem direito à proteção contra interferência prejudicial e não pode causar interferência em sistemas devidamente autorizados.

## CE Marking

CE marking on this product represents the product is in compliance with all directives that are applicable to it.



### Country List



AT	BE	BG	CY	CZ	DE	DK	EE	EL	ES	FI	FR	HR	HU
IE	IT	LV	LT	LU	MT	NL	PL	PT	RO	SE	SI	SK	UK

BFWA (Broadband Fixed Wireless Access) members noted in blue



**Note:** This device meets Max. TX power limit per ETSI regulations.

The following apply to products that operate in the 5 GHz frequency range:



## NBE-5AC-Gen2 Quick Start Guide



**Note:** All countries listed may operate at 30 dBm. BFWA member states may operate at 36 dBm.



**Note:** Operation in the 5.8 GHz frequency band is prohibited in BFWA member states. Other countries listed may use the 5.8 GHz frequency band.

### WEEE Compliance Statement

### Declaration of Conformity

### Online Resources



© 2020 Ubiquiti Inc. All rights reserved.